



PO Box 19-733
Woolston
Christchurch

Naval Point News

VOLUME 1 ISSUE 5

NOVEMBER 2006



INSIDE THIS ISSUE:

Commodores Comment	1
New Members	2
Courses	3
Classifieds	4
Sou'wester	5
Finn Canterbury Champs	6
Dinghy Report	7

Commodores Comment

Here we are..... Almost time to tear another page from the calendar and reflect on the season to date. Wind? Yes, heaps. Southerlies and rain? More than our share. Nor'westers?. Whew! Yet through all that there has still been some great tussles on the water and fleet numbers have been comparative to recent seasons. It proves we are a resilient lot and not put off by errant meteorologists. Speaking of which if you missed the address by Ken Ring at November's Noggin'n' Natter you missed a thought provoking theory on the evolution of our weather, and the effect the lunar cycle has on our patch. Skeptical? Time will tell if he's the man he says he is as we progress through 2007 and get to compare the actuals with his theories. Twilights for this side of Christmas are done and dusted and this midweek event has proven as popular as ever. Well done to Malcolm Ramsay and Ray Dunick who have manned the start box throughout the series and brought us the results on time with just a hint of assistance from Ross May. Learn to Sail has now completed its pre Christmas course, but I note several of the participants are keen to enroll in the New Year course as well. Keen? You bet! And all thanks to a small team led by Alistair Donaldson with assistance from Ryan and Kate Waghorn and the ever present Ross May. If you've been harbour gazing recently you may have noticed the lack of activity from the 420s. That's 'cos they're up country competing, and from there will be off to the World Champs. Well that's what we're hoping. Best of luck guys and girls.

A quick heads up on the Charity Race. It's all go thanks to the efforts of John de Boer and a very able and keen team from Smiths City Group. As I've mentioned in past letters Smiths Group underwrote the event which in essence gave Naval Point Club the confidence to move the whole affair to a much higher plane than we'd have been comfortable with in the past. The charity chosen is doctor Phillip Bagshaw's new Charity Hospital, and the specific piece of medical equipment identified is a surgery device that assists in cataract removal. Don't ya just feel good!! For those of you not at the Pint to Pint (yep, I got wet..... again) you missed a great day, and the Rescue Boat crews did their best to extract revenge for all those hours waiting around just for you. Water cannon and buckets were allowed, but we may have to forgo the flour bombs in future events. The main prize of the Rimu bookcase was won by "Springloaded" with a full house hand of aces and tens. Made our hand of a pair of eights look a bit sick..... and we thought we were looking pretty good! The Christmas party afterwards was a fun filled event as usual. Yep, those damned Pirates were back. Santa this year was joined by Mistress Claus and made many little ones eyes pop. Mark Quail and his team can take a bow for a job well done. Naval Point Club is a many faceted organization that is heavily reliant on the assistance of volunteers. As 2006 draws to a close I would like us to reflect what that help means to us all. I take this opportunity to wish you all a very Merry Christmas and a joyous and prosperous New Year. Where ever the break takes you take care and whatever you do, enjoy yourself.

Graham Moffat - Commodore



Welcome to the following new members

Roger Harding	Full member with boat Tasman 20 "Misty"	
Christiana Thannheiser	Full member	
Stephen Tubb	Family with Boat	Macgregor 26
"Tinel"		
Linda Burrowes		
Emily Tubb		
Alana Tubb		
Leah Tubb		
Braden Tubb		
Kerstin Bain	Family with boat	Buccaneer 525
David Bain		
Dominic Bain		
Timothy Bain		
Stuart Gough	Full member with boat	TY "Rigor Mortis"
Michelle Hintz	Full member with boat	Huntsman 5.5
Sonya Donaldson	Full Member	

Naval Point Clothing Range

CAPS:	\$20.00 ** New Item***
T – SHIRTS:	\$20.00 ** New Item***
POLOS:	\$35.00 ** New Item***
RUGBY JERSEYS:	\$80.00
VESTS:	\$85.00
CLUB TIES:	\$10.00

NAVAL POINT PIRATES WINE:

\$20.00 A BOTTLE
 \$180.00 CASE.
 PIRATES BLOOD (red)
 & PIRATES PLONK(white)

SAILING CALENDARS \$20.00

The Club Accepts Eftpos & Credit Cards.
 See Merchandise page on website for pictures.

Remember All Profits Go Back Into Your Club:

Courses and Events

Trailer Yacht Coaching

The second Trailer Yacht coaching day was completed on December 10.

A group of eleven sailors on three boats covered a range of topics including boat setup, launching, local cruising, weather changes and spinnaker setting.

An enjoyable and productive day was had by all involved.

More Courses

We have had some interest in VHF and GPS courses but need more participants before a course is viable.

If you are interested in Day Skipper, Boatmaster, Marine VHF, Basic GPS, Outboard Engine Maintenance Basic Sea Survival or Powerboat Courses you can collect more information from the Club Office. We are interested in hearing of your interests. Ring 328 7029 during office hours.

Keelboat Clinic

With a very busy competitive programme in March a two day keelboat coaching clinic has been planned for February 24 and 25 at NPCL.

Specialist coaches will be present.

Interested sailors are requested to register their interest with the club office.

3.7 dinghy National Championship.

To be held at NPCL over January 26 to 29.

Doyle Sailmakers South Island Young 88 Championships

Organised by NPCL on March 3 and 4.

Notice of Race available on the Club website.

Presidents Cup Keelboat Canterbury Championships

At NPCL March 10 and 11.

South Island Trailer Yacht Championships

Hosted by NPCL in cooperation with CTYS.

To be held on 7 and 8 April (Easter)

Notice of Race available on the Club website.

Pint to Pint Action



Classifieds

For Sale

Trailer Yacht - Catalina 23 "Shearwater"
1992 Hull, New Rigging, new sheets, 15HP Mercury
Toilet, Radio, Depth finder
Good strong family boat.
Price \$15,500
Phone Brian 3594169 or 0272779786

For Sale

Single axle, high sided trailer.
At present in the Club Haulout area.
To be sold on an "As is where is" basis.
Offers wanted.
Call Evan at during work hours on 328 8067

To Buy

Laser hull, with or without rig.
Any reasonable boat considered.
Call Ken during office hours on 328 7029

The Waikawa Drystack a new dimension to the boat storage and berth holder services at Waikawa Marina

- Secure indoor storage for 243 boats up to 12 metres
- Vessels launched and retrieved upon request
- Comprehensive range of auxiliary services from refueling, maintenance and repairs to valet services and provisioning
- License options available for 1 year (annual license) or 15 years (transferable)
- The ultimate solution for convenience, maintenance and on-going protection of your asset

**No worries. No hassles. Great service.
More time to enjoy boating.**

Detailed information available on our website
www.marlbroughmarinas.co.nz

Enquire NOW via email on drystack@pmnz.co.nz, or
call Jeamine Paul, Marinas Manager,
Port Marlborough Phone (03) 520 3306

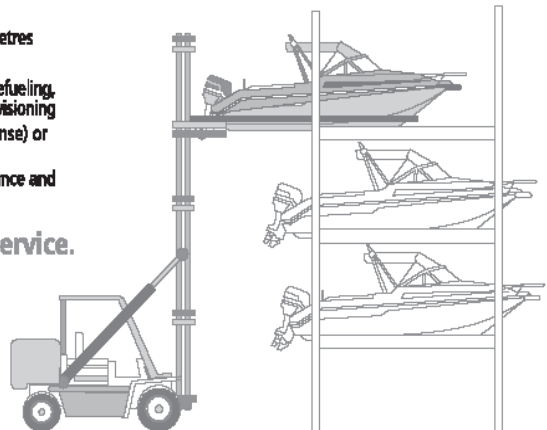

MARLBOROUGH SOUNDS
MARINAS III

PORT marlbrough
NEW ZEALAND LTD

The Marlborough Sounds Marinas are owned and operated
by Port Marlborough New Zealand Limited.

Port Marlborough New Zealand Limited
14 Auckland Street PO Box 111,
Picton, New Zealand

Sou'wester approaches

A hot dry nor'west wind thumps the house in anger. It's dying, and the last throws of it's blazing breath are felt hard and heated against the windows.

The sou'wester approaches.

Looking down across the harbour I can see the cat paws patting the calm water. The hills are standing in dull relief against the gathering front. Boiling cumulus moves silently behind the stark outline, dark gray and menacing. Above light wisps of cirrus dim the sun. Great powerful forces are at work. I look in awe at this happening right in front of me. The hills are suspended in an atavistic time warp, primal and unconcerned. Their round forgiving shapes are testimony to the blasts of countless centuries numberless storms. They have seen this happening since the earth spewed them into existence, this is their future and passed... they are calm and indifferent.

Rushing over the mountains surging violent and malevolent through the valleys, pouring it's torrents over the gridded pastures of the plains...

On it comes... relentless and dominant

Swallowing in gray gulps the foot hills and meadows.

On and on it comes.

Forest pines like lost steeples show dark green through the murky veil, reeling in an ecstatic and endless dance with nature

In a last frenzied blast the nor'west shakes the house in frustration. It's ephemeral end is near, to be replaced by the cold sou'west wind.

Great torrents of cloud pour over the harbour hills like invading ghosts, the nor'west has gone.

Temperatures drop..

The gray wiggled crags of Mount Herbert stare bleak as depressed lawyers through the sheeting downpore. Columns of marching rain dismal and defiant make the harbour water scurry in small agitated wavelet's.

The sou'wester is split by Quail Island, around King Billy it comes, erupting on Rapaki to the north, being compressed by the hills, it gathers its strength. To the south the houses in Charteris Bay seem to huddle against the hillside for protection. The dam has burst, a wild river of wind screams either side of the island. A dense ashen curtain thunders up the harbour making the water smoke and boil.

The first heavy drops of rain against the window obscure my view. Turning all into a streaming enigmatic blur.

It has arrived powerful and all consuming.

Anonymous

*"It has arrived powerful
and all consuming."*



Canterbury Finn Championships 2006/2007

The Canterbury Finn Championships for 2006/07 were sailed at the Charteris Bay Yacht Club on 2-3 December. The format was 3 races back to back each day. The racing was well and tightly run with the tail enders barely having time to catch their breath before the warning signal for the next race. For the first day of racing the wind was from the north east 20 knots gusting 25. While this wind did generate some waves they were smaller than the fleet is used to on other parts of Lyttelton Harbour.

Conditions for Sunday's racing were similar but the wind had dropped to about 15 knots. Line honours were shared equally by Ben Winters, the eventual winner, and Denis Mowbray. Denis's chances were reduced when the prod of a capsized R-Class went through his sail between races (don't ask how) and he had to withdraw. Chris Wells, defending champion, was very consistent with seconds for all races to count. Maurice Duncan and Ralf Traber had their own battle close behind the others.

It was good to see Matt Arthur back on the water. Mike Pearson was a welcome addition to the fleet having put a new sail on Ben's old boat, but a collision of his head with the boom (haven't we all done that) meant a withdrawal for stitches and advice to stop racing for a week or two. CBYC confirmed its legendary hospitality.

The results are in the table below:
Maurice Duncan

Final Results for Class = Finn
Sailed:6 Discards:1 To count:5 Entries:7

Helm	R1	R2	R3	R4	R5	R6	Total	Nett	Rank
Ben Winters	3	1	1 8.0	1	2	3	11	8	1st
Denis Mowbray	1	3	dnf	3	1	1	17	9	2nd
Chris Wells	2	2	2	2	3	2	13	10	3rd
Ralph Traber	4	5	4	4	4	4	25	20	4th
Maurice Duncan	5	4 8.0	3 8.0	5	5	5	27	22	5th
Matt Arthur	6 8.0	dns 8.0	dns 8.0	DNC	DNC	DNC	46	38	6th
Mike Pearson	dnf	dns	dns	DNC	DNC	DNC	48	40	7th

Christmas Greetings

I take this opportunity to wish you all a very Merry Christmas and a joyous and prosperous New Year. Where ever the break takes you take care and whatever you do, enjoy yourself.

Graham Moffat (Commodore)



Coaching & Dinghy Report

Learn to Sail

We are down to 9 regular learn-to-sail skippers from the original 11, plus Sam Kuipers has tagged onto the fleet. The conditions have been challenging for the skippers and the team running the program with strong Westerlies on 3 of the 5 sailing days. We offered a Friday night as a catch up session and only one person, Scott turned up so he received some good tuition from Kate and Ryan. The following Saturday, 2 December was a vast improvement with a building easterly. Scott showed his newly learned skills with him, Taylor Balogh and Sam Kuipers sailing out to the clearer water by the breakwater. Ryan and Paul Kuipers coached them from the rescue boat, with the boys enjoying the sailing in the less congested area. The remaining group enjoyed a sail around the cans in the confines of the launching area, this then progressed to sculling races and water fights. The kids enjoyed themselves with the two Philpott girls performing some lively raids on the boys. The boys who ventured out further thoroughly enjoyed it and in their own words "it was awesome!"

Junior and Youth Classes

November saw some good fleets of junior and youth classes sailing, plus we have had the Starling Match Racing Trials and P Class Tanner Cup Trials.

There is a good fleet of P Class regularly sailing at the club with Brent Cowan promoting coaching and the growth of the class. The Opti, P and Starling are very much regatta driven classes so we will see good fleets when we hold a regatta but these fleets will be non existent when other clubs hold regattas.

We will have good NPCL representation at the P and Starling Nationals in Nelson in late January with:

Kate Waghorn, Gabrielle Cross, Brendan Campbell, Morgan Cowan, Mike Anderson, Layton Hern and Daniel Philpott are all attending the Tauranga Cup.

Kate Waghorn, Gabrielle Cross, Ryan Donaldson, Mike Glassford, Matt Hern, Ashley Campbell and Todd Wells are all attending the Starling Nationals.

Dinghies

The Hobie Nationals are in Wellington in early January, Warren Guy/Peter Evrard and Ryan Thompson/Ryan Donaldson will be representing NPCL.

The 420 teams will be in Auckland later in December for approx a month sailing in the 420 trials, pre worlds if selected and then the worlds in early January.

Naval Point is the venue for the Farr 3.7 Nationals in late January.

The Zephyrs have their Nationals in Akaroa in January also with Matt Hannah showing good form in recent Canterbury Champs races.

Events

Graham Mander Trophy at CYC 9 – 11 December. Won by Kate Waghorn of NPCL . Well done

Starling and P South Islands, Nelson Yacht Club 16 & 17 December. NPCL members Kate Waghorn (3rd in P Class) and Ryan Donaldson (4th in Starlings)

420 Worlds

Three Naval Point members are vying to represent New Zealand at the World 420 Championships to be held in Auckland early next year.

Hayley Anderson, Ashleigh Campbell and Danielle Bowater are all trying to gain selection.

During December selection regattas will be sailed, with the New Zealand team announced at the end of December.

All those competing are a product of the Canterbury Sailing Academy which is working well in developing very talented youth sailors.

We will have many club members competing at National and International level over the next 2 months, We all wish them the best and trust they will represent our club well.

Naval Point Club Lyttelton Inc

Phone: (03) 328 7029

Fax: (03) 328 9287

E-mail: secretary@navalpoint.co.nz

Website: www.navalpoint.co.nz